

SOUND ABSORPTION COEFFICIENT OF PERFORATED PLYWOOD: AN EXPERIMENTAL CASE STUDY

ABSTRACT: For sound control in closed spaces, perforated wood-based panels are widely used as walls and ceilings covering for their sound absorption properties in the low frequency range. Despite the high interest in this products, accurate estimation models of their properties are still unavailable. This paper reports the sound absorption properties determined for drilled okoumé plywood intended for interiors covering. The drilling percentage was fixed at 1.5, while different cavity sizes were arranged behind the specimens to evaluate their influence on the sound absorption. Tests were performed by means of the impedance tube method. The experimental data obtained can be used for the development of new estimation models with increased accuracy.

KEYWORDS: sound absorption, perforated panels, plywood

1 INTRODUCTION

Sound absorption in enclosures constitutes a relevant topic for many building applications, in particular with respect to large scale structures like public buildings, offices, shopping centres or dining spaces. Such environments, in fact, are often characterized by high noise levels, especially when crowded.

Depending on the building typology, many sources contribute to increase the overall noise: people's voice (Fig. 1), movements, air-conditioning systems etc. Poor acoustics of enclosed spaces can deeply rebound on their usability, particularly with respect to the speech intelligibility.

To mention some example, high levels of noise in classrooms make students prematurely tired getting worse the efficiency of learning [2]; speech communication between diners in college halls is recognized to be generally poor [3], while the quality of communication in food courts of shopping centres is strongly affected by ambient noise [4]; finally, poor acoustics in offices can affect the working quality and cause increased stress to workers [1].

Focusing on offices, a recent study performed by Jensen and Arens [5] indicated that acoustic discomfort is perceived by workers as a critical issue in these environments.

¹ Francesco Negro, AGROSELVITER Dept., University of Torino, Via Leonardo da Vinci 44, 10095 Grugliasco, Italy. Email: francesco.negro@unito.it

¹ Corrado Cremonini, Email: corrado.cremonini@unito.it

² Milena Properzi, BFH-AHB, Bernerfachhochschule, Solothurnstrasse 102, Postfach, CH-2500 Biel 6, Switzerland. Email: milena.properzi@bfh.ch

¹ Roberto Zanuttini, Email: roberto.zanuttini@unito.it

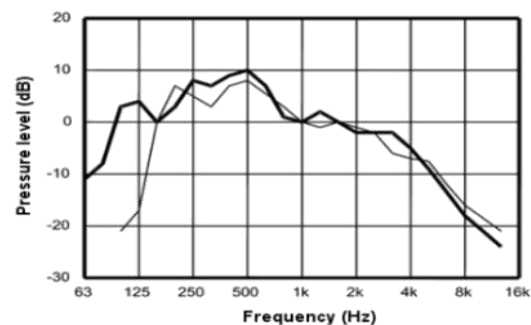

Figure 1: Average spectra of normal male (thick line) and female (thin line) speech (from [1])

That study consisted in a survey performed on over 23.000 occupant of office workstations, which rated nine factors of their environment (acoustic comfort, thermal comfort, air quality, lightning, cleanliness etc.). The collected answers pointed out that acoustic comfort reaches the lowest satisfaction score among the different categories. In particular, satisfaction with noise level and speech privacy turned out to be both problematic.

On the whole, the above mentioned situations evidence how acoustic control plays a fundamental role. Solutions for acoustic improvement are particularly important for noise emitted in the low frequency range, i.e. below 1600 Hz (Fig. 2).



This page not for sale study

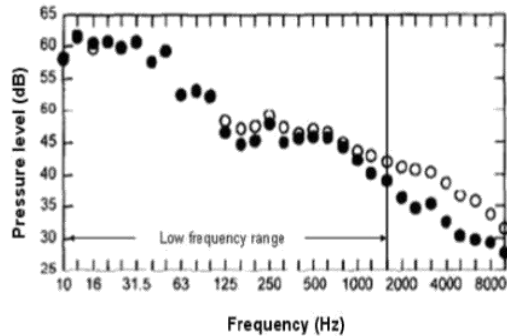

Figure 2: Example of noise spectra produced in an office with 24 workers: ○ within office hours; ● during lunch time (modified from [1])

Furthermore, a peculiar phenomenon of enclosed spaces is reverberation, which can be defined as the build up of sound due to wave reflections on all space surfaces. Reverberation creates a background noise, contributing to increase the overall noise of the room and lowering the speech intelligibility. Usually, this is evaluated by means of the reverberation time RT_{60} , which is the time required for reflections of a direct sound to decay by 60 dB below its level.

RT_{60} is calculated by means of Equation (1)

$$RT_{60} = \frac{0.161V}{A} \quad (1)$$

where V is the volume of the room in m^3 and A is the total absorption of the room, in sabines (absorption unit, equivalent to the absorption by a square meter of a surface absorbing all the incident sound).

Ideal RT_{60} depends on the intended purpose of a room and its volume. Higher RT_{60} values are needed in rooms where music is played; on the contrary, lower RT_{60} values are desirable for rooms mainly used for speech. According to equation (1), RT_{60} can be controlled in two main ways: modifying the room size or changing the amount of absorption on its surfaces. The second is particularly suited for large scale buildings.

In fact, when a sound wave strikes a material, a fraction of the sound energy is reflected back while another is absorbed. The absorption coefficient ranges from 0 (no absorption) to 1 (full absorption) and represents the ratio between the absorbed and the total incident energy. The theoretical limit of the sound absorption coefficient (α) is 1, when all the incident sound is absorbed. Nowadays several efficient methods are used for improving the acoustic features of large scale enclosures [6].

The adopted solutions vary from the design of room shapes, to the control of sound sources and to the use of sound proof materials or sound traps. Among the different approaches, the choice of perforated wood-based panels for exploiting their sound absorption properties is widely diffused.

These panels act both by absorbing the direct sound and by shortening the reverberation time, since they increase

component A in equation (1). Beside their absorption behavior in the low frequency range, perforated wood-based panels are appreciated by architects for many other reasons.

In particular they are used for their relative lightness, valuable look, easy lying, sustainability and recyclability. These panels are diffused as ceilings or walls covering (Fig. 3) leaving a space between panels and the wall at the back. This cavity can be empty or further filled with sound absorbing materials.

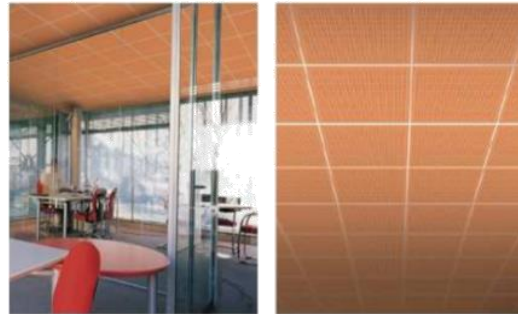

Figure 3: Application of wood-based perforated panels as a ceiling and wall covering [from 7]

The combination of perforated panel with an empty space at the back works like an Helmholtz resonator [8,9,10]. This is constituted by two communicating volumes called neck and cavity, which form a mechanical mass-spring system.

When struck by a sound wave, the air contained in the neck (the mass) is pushed into the cavity. As a consequence, the air of the cavity is compressed and reacts (like a spring) expanding and pushing out the incoming air. Hence this air is driven outside and, having a momentum, goes a little beyond the neck. For this reason, the air in the cavity becomes rarefied and recalls inside other air restarting the cycle.

The mass-spring action is able to absorb high amounts of sound energy, which is converted into the air swing. This phenomenon occurs in particular around a specific resonance frequency, at which the maximal sound absorption is provided.

The absorption properties of the system are mainly influenced by the volumes of neck and cavity. Changing in these volumes determines different amounts of absorption and slides the frequency around which absorption is greater.

In particular, the volume V of a Helmholtz cavity having circular or rectangular section can be calculated using Equation (2):

$$V = a \cdot t \quad (2)$$

where a is the area of the section and t is the thickness of the cavity.

Clearly, when the area a is constant, the only way to change the volume V is to modify the thickness t . Other variables, such as shape of the neck or geometry of the

cavity, play a minor role in determining the absorption values.

Transferring the Helmholtz principle to the perforated panels, holes in the panel represent the neck, while the empty space between panel and wall constitutes the cavity (Fig. 4).

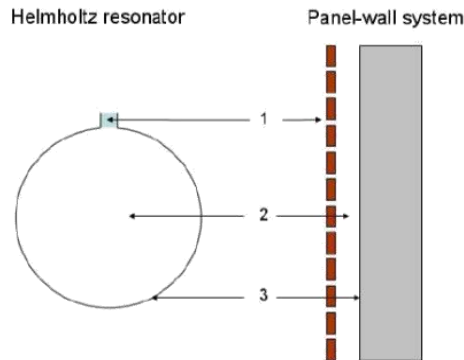

Figure 4: Longitudinal section of a Helmholtz resonator (left) and a system made of perforated panel and wall (right). 1 is the neck in the resonator, corresponding to the holes in the wood-based panel; 2 is the cavity, corresponding to the empty space between panel and wall; 3 is the cavity surface, which corresponds to the wall

Figure 5 reports an example of sound absorption values achieved by perforated wood-based panels intended for walls and ceilings covering and currently available on the market. These panels are able to provide high sound absorption in the low frequency range, therefore where is particularly needed for acoustic control in large scale buildings.

Furthermore, the absorption values are higher than 0.8 from about 300 to 1500 Hz. As a consequence, the absorption effect is consistent not only in correspondence of the resonance frequency but also in a wide range around it.

It must be noticed that in figure 5 peak values of α exceed 1. This apparent contradiction with the theory can be attributed to the experimental measurement method. Anyway, in these cases the absorption value can be considered as 1.

Since 1947, several studies have been carried out in order to investigate the sound absorption coefficients of perforated panels. Nevertheless, up to now accurate estimation models are still unavailable and the only means of evaluating the sound absorption behavior of a certain panel is still to perform experimental measurements [11].

Setting up new models with increased accuracy would positively rebound on design and development of fit to purpose perforated panels, in terms of costs and efficiency. In this context, the present work takes into account the influence of cavity size on the sound absorption properties of perforated plywood.

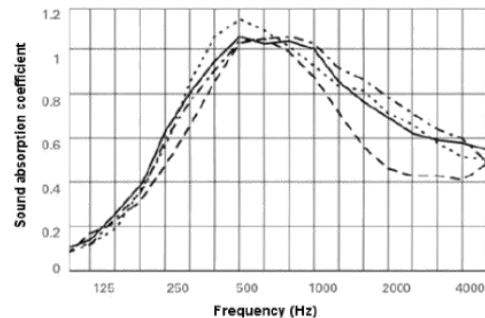

Figure 5: Sound absorption values of perforated wood-based panels with different passing light percentages: — (6.0%); (7.0%); - · - · (7.5%); - - - (12.0%) [from 7]

To this purpose, test were performed on specimens with a fixed drilling pattern, while different cavity thickness were arranged behind. Changing the cavity thickness, in fact, represents an easy way for modifying the absorption behaviour of a certain panel.

The results of this preliminary experimentation provide detailed indications, which in literature are still limited, concerning the values of resonance frequency associated to cavity thickness variations.

2 MATERIALS AND METHODS

For the present work okoumé (*Acosmea klaineana* Pierre) plywood was chosen as a lightweight and nice looking wood-based product adequate for ceilings and walls covering. Nowadays okoumé timber is mainly destined for the production of plywood, whose main end-uses are furniture components, interior joinery and interior panelling both in building sector and in marine craft [12].

2.1 THE WOOD-BASED PANEL

The okoumé plywood used for this work was 4 mm thick with 3-layers composition. The veneers were glued by means of a MUF (melamine-urea-formaldehyde) adhesive system and the panel was complying the class 2 of EN 314-2 for use in humid conditions [13]. The mean density was 460 kg/m³.

2.2 THE KUNDT'S TUBE TEST

To measure diffuse sound incidence, the coefficient can be determined through the reverberation room method, in accordance with EN ISO 354 [14]. However, this requires large-sized samples and is not suitable for material at development stages.

An alternative is represented by the impedance tube (Kundt's tube) method, which is limited to normal incidence sound but, requiring smaller samples, is better for research activity. Hence, in this work the normal incidence sound absorption coefficient was determined by the impedance tube method (Fig. 6), according to EN ISO 10534-2 [15].

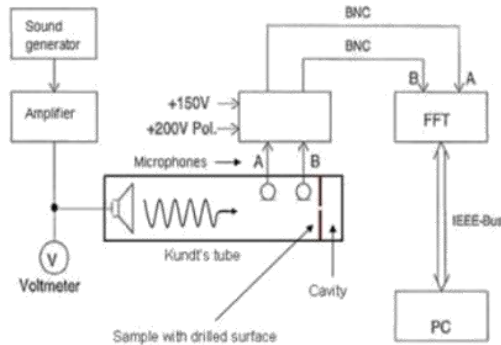

Figure 6: Outline of the test method device, mainly constituted by a sound generator, the Kundt's tube, two microphones, a FFT analyser and a PC for data processing

This method requires to place the specimen at one end of a cylindrical impedance tube. Plane waves are then generated in the tube by a sound source and the relative pressures are measured by two microphones positioned near to the specimen.

The complex acoustic transfer function of the signal is determined and used to compute the normal incidence absorption coefficient.

This is calculated by means of Equation (3)

$$\alpha = 1 - |r|^2 \quad (3)$$

in which the normal incidence reflection factor (r) is estimated for frequencies ranging from 50 to 1.600 Hz according to Equation (4) :

$$r = \frac{H_{12} - H_I}{H_R - H_{12}} e^{2jk_0x_1} \quad (4)$$

where H_{12} is the transfer function for the total sound field, H_I is the transfer function for the incident wave alone, H_R is the transfer function for the reflected wave alone, j is $\sqrt{-1}$, k_0 is the wave number (ratio of angular frequency to sound speed), and x_1 is the distance between the specimen surface and the closer microphone in the tube.

2.3 THE SPECIMENS

Circular specimens with 99.8 mm diameter were obtained from okoumé plywood. These were cut using a computer numerical control (CNC) milling cutter (Fig. 7), in order to achieve the high dimensional accuracy required by the test (+0.0; -0.1 mm).

Such a precision is necessary for assuring the complete contact between the circular border of the specimen and the inner circumference of the tube. In fact, even small voids would alter the volume of the cavity and consequently influence the test results.

After cutting, specimens were perforated using a hand-drill. Holes diameters were then measured with a digital

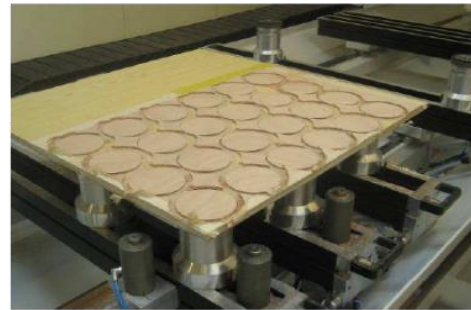

Figure 7: Cut of 24 circular specimens realized by means of a CNC milling cutter. Specimens were drilled and used for the Kundt's tube test

calliper in order to check the accuracy of their sizing. The adopted drilling pattern consisted of 9 holes with ray 2 mm, corresponding to 1.5% of drilling percentage (Fig. 8). Holes were symmetrically realized around specimens centre, complying with EN 10534-2.

In this work a single drilling pattern was realized, since the main aim was to evaluate how variations in cavity thickness influence the absorption properties of the system.

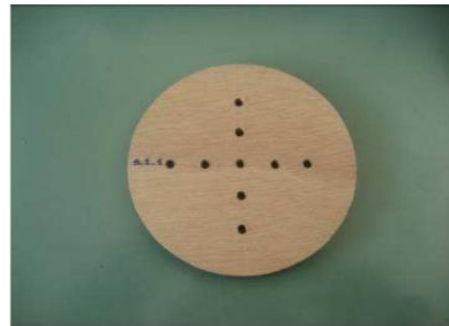

Figure 8: Tested specimen with diameter 99.8 mm and drilling pattern made of 9 holes of ray 2 mm symmetrically disposed

Specimens were laid in the Kundt's tube leaving an empty cavity between them and the metallic end of the tube. This setup allowed to simulate the laying conditions of the panels as wall-ceiling covering with an empty space at the back.

The cavity of the impedance tube was set in 7 different thickness, respectively 4.5, 9, 15, 22, 30, 60 and 80 mm. The section area of the cavity was fixed and coincident with the circular perimeter of the tube.

Therefore, changing the thickness was the only way to modify the volume and consequently the sound absorption properties of the tested system, as before mentioned in equation (2). The sound absorption amounts in the low frequency range were measured for each cavity thickness. Following reported data are the



average of 3 test repetitions as recommended by EN 10534-2.

While in this testing procedure the only varying parameter was the cavity thickness, in design and production stages the desired sound absorption properties of a certain panel can be obtained by varying holes number, holes diameter or neck thickness.

Aim of the present work was anyway to focus on the influence of cavity thickness. Finally, in order to know the absorption properties of the panel, the above described test was also performed on an undrilled specimen.

3 RESULTS AND DISCUSSION

Before to focus on other results, Figure 9 shows the sound absorption measured in the low frequency range for the undrilled plywood panel.

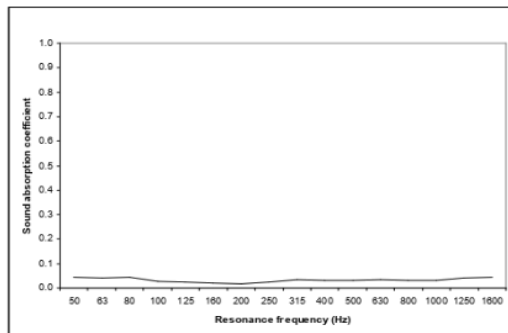

Figure 9: Sound absorption values measured for the undrilled plywood panel

The above graph clearly indicates that 4 mm okoumé plywood is a sound reflecting material. In fact, its sound absorption coefficient varies from 0.02 to 0.04 in the whole low frequency range. This confirms the low values commonly reported regarding the sound absorbing behavior of wood and plywood [16].

Figure 10 illustrates the sound absorption values obtained in the low frequency range for the testing specimens with different thickness of the cavities.

The comparison between figures 9 and 10 underlines how the system made of surface drilling and different cavity volume at the back can considerably improve the sound absorption behaviour.

Considering that the resonance frequency (f_r) of each curve is the frequency value (in Hz) at which the absorption peak is reached, the figure shows that the different curves are selective around their respective resonance frequency.

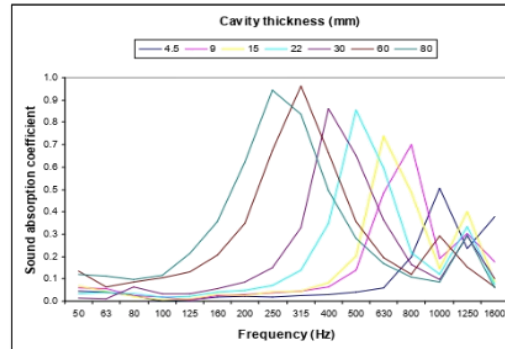

Figure 10: Sound absorption values measured for different cavity thickness

In fact, absorption values quickly decrease before and after the peaks. The values of absorption peaks and resonance frequencies depending on cavity thickness are also shown in Table 1.

Table 1: Cavity thickness of the Helmholtz system with correspondent resonance frequency and averaged absorption peak values

Cavity thickness (mm)	Resonance frequency (Hz)	Average absorption coefficient	std.dev.
4.5	1000	0.50	0.02
9	800	0.70	0.03
15	630	0.77	0.01
22	500	0.85	0.01
30	400	0.86	0.01
60	315	0.96	0.01
80	250	0.94	0.02

These data quantify how changing in cavity thickness determinate a slide of peaks towards lower frequencies. This phenomenon goes with a simultaneous increasing of the absorption peaks values, which grow from 0.50 for the 4.5 mm thick cavity to 0.94 for that of 80 mm. This is due to the increasing of the air volume included into the cavity, which becomes progressively more adequate to perform the spring effect of the Helmholtz system.

Figure 11 takes into account the peak values listed in Table 1. Each peak value is characterized by its specific cavity thickness and resonance frequency. The non-linear regression was performed considering cavity thickness as the independent variable and resonance frequency as the dependent one.



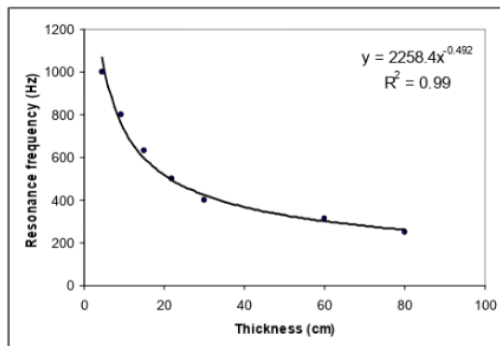

Figure 11: Cavity thickness vs. resonance frequency of the absorption peaks

The regression was performed using the power Equation (5)

$$y = ax^b \quad (5)$$

The power form was chosen to attain to the physical law explaining the resonance frequency ω_H of an ideal Helmholtz resonator. In fact, ω_H is given by the basic Equation (6)

$$\omega_H = c_0 \sqrt{\frac{S}{LV}} \quad (6)$$

where c_0 is the sound speed, S is the hole area, L is the depth of the open hole and V is the volume of the empty cavity [8].

Since the only varying parameter was the cavity thickness, the only variable in (6) is the volume V , while S and L can be considered as constants. Therefore the Equation can be rewritten as (7)

$$\omega_H = aV^{-0.5} \quad (7)$$

where a is a constant and V is the volume of the cavity. The coefficients found for Equation 4 through the regression are given in Equation (8)

$$y = 2258.4x^{-0.492} \quad (8)$$

for which R^2 resulted 0.99 (p -value < 0.001). This suggests that the experimental results strictly attain to the physical law of the Helmholtz resonance.

Hence, the coefficients found through this method are reliable and suitable to be used for the development of new estimation models.

Finally, figure 12 shows the correlation between resonance frequency and sound absorption coefficient of the peak values.

The performed correlation assumes the linear form of equation (9)

$$y = -0.0006x + 1.1184 \quad (9)$$

for which r resulted -0.98 (p -value < 0.001).

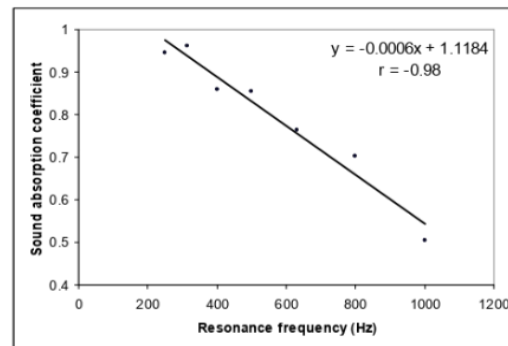

Figure 12: Negative linear correlation between resonance frequency and sound absorption coefficient achieved by the peaks

Figure 12 illustrates that for frequencies below 500 Hz the tested system is able to provide sound absorption coefficients higher than 0.80.

On the opposite, increasing in the resonance frequency determines a simultaneous decreasing of the system efficiency. For this reason, perforated wood-based panels are used for acoustic improvement in the low frequency range, while for sound control at medium and high frequency other products are preferred.

4 CONCLUSIONS

Nowadays many large scale buildings present poor acoustic performance, particularly with respect to the noise emitted in the low frequency range. For sound control in these environments, perforated wood-based panels are widely used as ceilings or walls covering thanks to their sound absorption properties.

Despite the interest in using and producing these panels, to this day accurate estimation models are still unavailable. As a consequence, the only means of evaluating the sound absorption behavior of a certain panel is to perform experimental measurements.

Therefore, the present work analyzed the absorption properties of drilled plywood with empty cavity at the back, in order to simulate the end-use laying conditions. The attention was focused on the influence of cavity thickness, since varying this parameter represents an easy way to modify the sound absorption properties of the panel.

The tested Helmholtz systems turned out able to achieve absorption values higher than 0.90 in the low frequency range. It was also found the regression equation explaining the resonance frequency values depending on cavity thickness.

The coefficients characterizing the regression equation will be further used for R&D activity. In particular, the experimentation will be repeated using different sets of drilling patterns, panel thickness and cavity size, in order to obtain a wider dataset and constitute a large number of regression equations characterizing the different Helmholtz systems.



The aim is to contribute to the elaboration of reliable models explaining the absorption properties of perforated plywood depending on the cavity thickness at their back. Accurate models could enable to fit the absorption properties of a certain panel to the specific needs of the enclosure in which it will be used just by varying the cavity sizing. This represents an easy way to calibrate the acoustic control of an enclosed space and might be particularly relevant in acoustic complex environments such as large scale buildings.

ACKNOWLEDGEMENT

The authors would like to thank Compensati Toro S.p.A., for supporting the realisation of the work; Dr. Marco Fringuellino, for his contribution on acoustical analysis; Dr. Rudolf Bütikofer and the Acoustic Department of EMPA, Dübendorf, Switzerland, for making possible testing with the impedance tube.

REFERENCES

- [1] Tang S.K., Chan J.W.C. Some characteristics of noise in air-conditioned landscaped offices. *Appl. Acoust.*, 48(3):249-267, 1996.
- [2] Trombetta Zannin P.H., Zanardo Zvirtes D.P. Evaluation of the acoustic performance of classrooms in public schools. *Appl. Acoust.*, 70(4):626-635, 2009.
- [3] White A. The effect of the building environment on occupants: the acoustics of dining spaces. MPhil dissertation, University of Cambridge, UK, 1999.
- [4] Porto Nunes Navarro M., Leal Pimentel R. Speech interference in food courts of shopping centres. *Appl. Acoust.*, 68(3):364-375, 2007.
- [5] Jensen K., and Arens E. Acoustic quality in office workstations, as assessed by occupant surveys. Proceedings of Indoor air: 10th International Conference on Indoor Air quality and Climate, Beijing, China, Sept. 4th-9th, 2005.
- [6] Fuchs H.V., Zha X., Zhou X., Drotleff H. Creating low noise environments in communication rooms. *Appl. Acoust.*, 62(12):1375-1396, 2001.
- [7] Patt (Ed.). AP - Acoustic paneling. Patt Spa, Udine, Italy, 2010
- [8] Fasold V., Veres E. Sound protection and room acoustics in practice: design examples and building solutions (German). Verlag für Bauwesen, Berlin, Germany, 1998.
- [9] Rossing T.D. (Ed.) Springer handbook of acoustics. Springer, Würzburg, Germany, 2007.
- [10] Everest F.A., Pohlmann K.C. Master handbook of acoustics 5th edition. McGraw-Hill, USA, 2009.
- [11] Lin M.D., Tsai K.T., Su B.S. Estimating the sound absorption coefficients of perforated wooden panels by using artificial neural networks. *Appl. Acoust.*, 70(1):31-40, 2009.
- [12] Brunck F., Grison F., Maître H.F. L'okoumé Aucoumea klaineana Pierre: monographie. CIRAD-CTFT, Nogent-sur-Marne, France, 1990.
- [13] EN 314-2:1993. Plywood. Bonding quality. Part 2: requirements.
- [14] EN ISO 354:2003. Acoustics. Measurement of sound absorption in a reverberation room.
- [15] EN 10534-2:2001. Acoustics. Determination of sound absorption coefficient and impedance in impedance tubes. Part 2: transfer-function method.
- [16] Bucur V. Acoustics of wood. CRC Press, Boca Raton, Florida, 1995.



This page not completed study